

## Tigex<sup>®</sup> Gas-Tight Draught Stabilisers

NEW PRODUCT

With new adapter for  
pipe size: Ø80 mm



Tigex 100



Tigex 150 Black



Tigex 180

Each size is available in Stainless Steel and Stainless Steel powder coated black

# Efficiency & reliability

## Tigex - important for boiler reliability and fuel efficiency.

How a heating system is installed will have great impact on reliability, overall efficiency and on the environment and should therefore be installed for optimal performance. It is important that the three main components; boiler, burner and chimney are suitable and work well together. The Chimney often receives the least amount of attention despite the fact that discrepancies in design or dimensioning could lead to serious problems.

Weather and wind conditions can vary drastically over the course of a year leading to a wide range of draught conditions in the chimney. On cold days with high wind conditions, the draught increases, while on calm, warm days there may be no draught at all. This leads to different draught conditions inside the fire chamber as the burner fan will give different amounts of air depending on the conditions. A properly dimensioned and correctly installed draught stabiliser will automatically and continuously allow only the necessary amount of combustion air to pass through the boiler resulting in an optimal efficiency rating.

Draught variations in the chimney influence the velocity of the exhaust fumes as they pass through the boiler, which effects heat exchange. For example, if draught conditions are too high when burning solid fuels, the time for carburetion and contact with the heat exchanger is too short, which leads to low thermal efficiency, poor combustion and eventually even problems in operation. Simply put, without a proper draught stabiliser, much of the heat produced in the boiler will be lost through the chimney.



## Tigex helps retain heat in the boiler

A correctly dimensioned, well functioning draught stabiliser will control the draught conditions in the boiler to maximise efficiency throughout the year. The temperatures in the chimney will be lower and the boiler will retain more heat.

# Energy savings

## Energy savings with a Draught Stabiliser

In measurements conducted for the table below, we can show the difference in energy losses on systems installed with and without draught stabilisers. The biggest energy losses in installations without draught stabilisers arise due to increased soot build up, breakdowns and unburned particles.

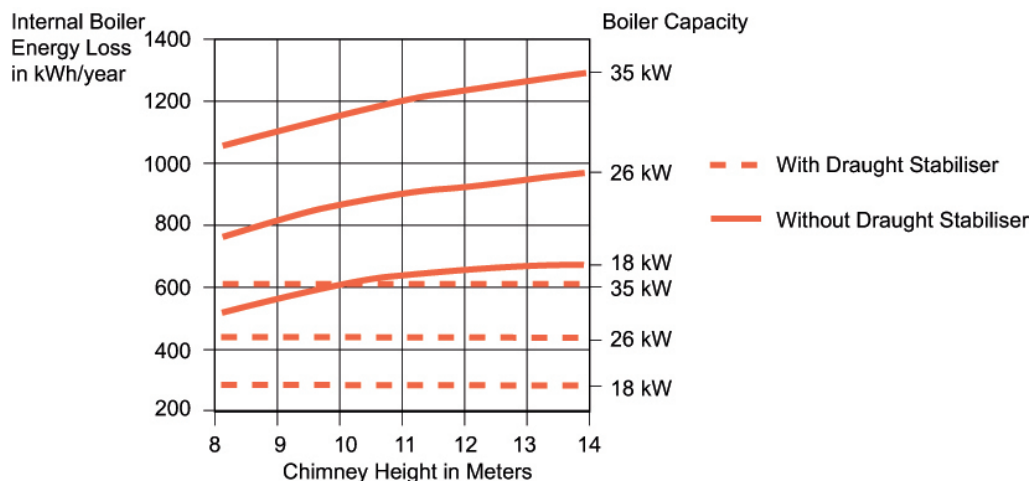

We can read from the table that the heating installation with a boiler capacity of 35 kW, chimney height 12 m, without a draught stabiliser, suffered inner boiler losses of 1.240 kWh/year. The same installation with a correctly dimensioned draught stabiliser only suffered losses of 600 kWh/year.

Experience has shown that the total yearly savings for an installation with a properly designed and installed draught stabiliser is up to 10%, depending on various conditions.



Irrespective of whether the boiler is fired with oil, gas, pellets or wood, a stable draught in the chimney is important for combustion conditions in the burner chamber.

# Prevent condensation

## Tigex will help prevent damages caused by condensation

Condensation in chimneys can occur due to a number of various factors. The condensation that runs along the inside walls of the chimney consists mainly of water, but also contains corrosive acids. This is extra sensitive in a brick chimney since condensation leads to erosion and cracks from freezing.



The material in a chimney always maintains a lower temperature than the exhaust gas. It is important that the exhaust gas temperature is at least 10° C above the dew point temperature when measured at 0,5 m from the top of the chimney.

Modern boilers have optimal thermal efficiency ratings with low exhaust temperatures and high CO<sub>2</sub> content. The requirements on design for small, easily installed boilers have led to reduced water volumes in boilers. Reduced water volume leads to shorter running cycles of the burner, which in turn can lead to increased condensation.

Old model boilers generally have higher exhaust gas temperatures with lower CO<sub>2</sub> content. This is because the old boilers were not air tight and burners were seldom equipped with self-closing dampers. This means the risk for condensation in such installations is lower, however energy consumption and the negative influence on the environment are much higher compared to new heating installations.

New burners with self-closing dampers and new tighter boilers are helping to reduce energy losses by reduced air flow through the boiler, which in itself improves efficiency over the year. This however, removes a degree of ventilation in the chimney that existed before, which creates a large risk for condensation. There is also a large risk for condensation on chimney installations that were done originally for an older boiler, as the area measurements are most often incorrect for the new and much more efficient boiler.

Installing a Tigex draught stabiliser will allow dry air from the boiler room to enter the chimney. This provides a certain amount of dilution to the exhaust gases during operation, which increases exhaust gas circulation and decreases the dew point by approx. 10° C. This also provides a certain amount of drying while the burner is in stand by position.

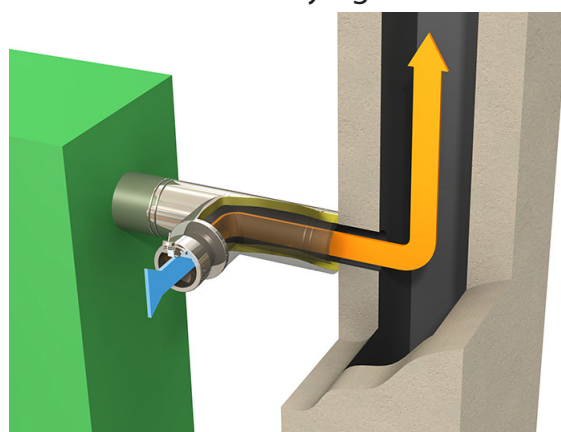

### Dew point

(temperature at which steam in exhaust gas starts to condensate)

Pellets: 45° C at 13% CO<sub>2</sub>

Oil: 47° C at 13% CO<sub>2</sub>

Gas: 57° C at 13% CO<sub>2</sub>

The dew point temperature varies depending on CO<sub>2</sub> content - the lower the CO<sub>2</sub> content, the lower the dew point.



# Advantages

## Stainless steel design

A draught stabiliser is located in a very tough environment, being exposed to soot particles, moisture and even corrosive chemicals. Tigex draught stabilisers are designed to the highest quality standards using high quality stainless steel and high-temp superwool sealing material. The materials and design of the Tigex will help it to maintain accuracy in regulating draught conditions for many years.

## Gas-tight design

The ingenious, gas-tight design of the Tigex 50 allows the damper flap to close tight against the seal at the opening. By mounting the damper flap axel on the rear (back side), away from the opening, there is no leakage of exhaust fumes through hinge or axel joints. This allows the Tigex 50 to close completely tight. The axel joint is also self-cleaning.

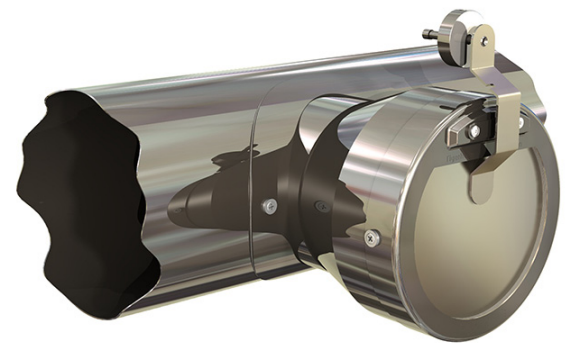

## Quiet operation

Tigex 50 will operate quietly thanks to the ingenious door design. The damper flap opens and closes quietly during operation as there are no metal parts hitting each other.



Tigex 100 adapter for round flue pipe Ø100 mm



Tigex 150 adapter for insulated T-pipe Ø200 mm. Also shown with protection grid

## Large range of adapters for flexibility

Due to our long experience as the leading manufacturer of draught stabilisers in Scandinavia, we have much experience in developing adapters to suit a variety of installation needs. Contact us for more information.

# Technical data

## Capacity

Model	Approx Capacity	Max. chimney height	Max. chimney dia. / area
Tigex 100	up to 25 kW	up to 8 m	Ø130 mm / 132 cm <sup>2</sup>
Tigex 150	up to 100 kW	up to 15 m	Ø200 mm / 314 cm <sup>2</sup>
Tigex 180	up to 250 kW	up to 15 m	Ø280 mm / 615 cm <sup>2</sup>

## DIN 4795

Tigex draught stabilisers have been vigorously tested according to DIN 4795.

Tigex 100 meets criteria for Air Group 1 - 2

Tigex 150 meets criteria for Air Group 1 - 4

Tigex 180 meets criteria for Air Group 1 - 5

The table above shows how the Tigex models stand in relation to the different air groups according to measurements specified in DIN 4795. The curves clearly show that the Tigex models meet or exceed the necessary air flow for the air group categories specified.

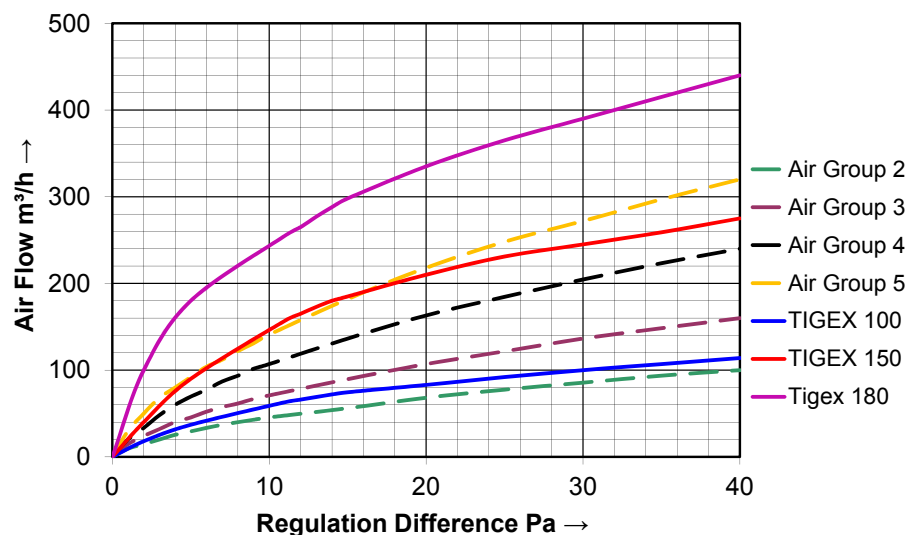

## Accuracy

The accuracy of a draught stabiliser is important to allow maximum potential energy savings and to help eliminate condensation in the chimney that can later lead to expensive damages. This table shows the accuracy of the Tigex 150 as it opens and closes (green area) at the desired setting (Black line).

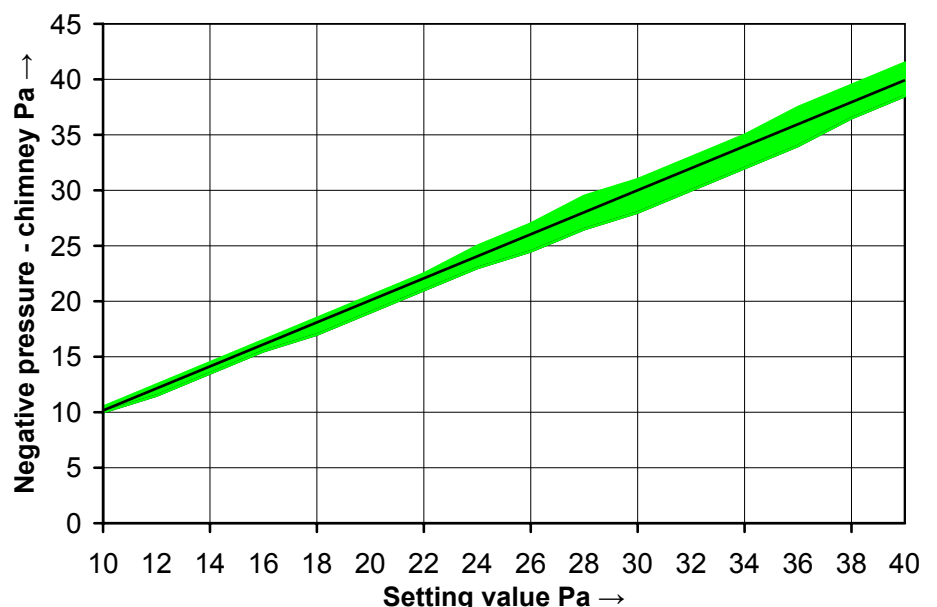

# Applications

## Wood and Pellet Stoves

The new Gas-Tight Tigex Series is perfect for pellet or wood burning stoves. The gas-tight design means that no exhaust fumes will leak into the heating area through the draught stabiliser. There is also an optional protection grid available .

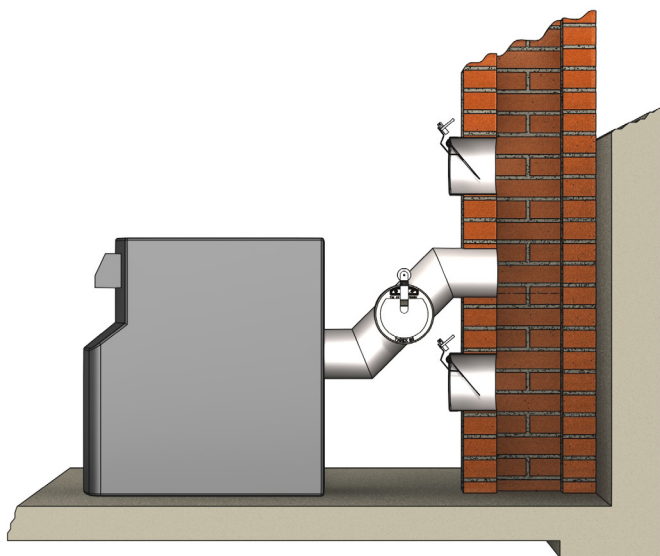
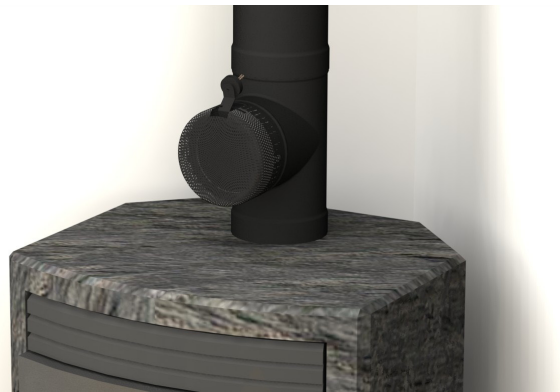

## Draught stabiliser location

The optimal placement depends mainly on the task it must fulfil. Possible placements include; on connection pipe directly after the boiler via an adapter for round pipes. It is possible to build it in the brickwork above the boiler or under the flue pipe. Special adapters must be used in the latter two cases for building into brickwork.

## Always install a Tigex

A large number of domestic oil boilers that are sold today are replacements for older heating installations. They are often connected to old chimneys and/or chimneys with insufficient insulation. These older chimneys often have an open area that is too large for today's modern and efficient boilers. When changing from oil heating to wood or pellets, the problem is often the opposite since smoke gas volumes increase when burning solid fuels, demanding a larger area.

The best solution is to install a correctly dimensioned stainless steel pipe in the chimney in combination with a Tigex draught stabiliser. Installing only the stainless steel pipe without a Tigex would make it impossible to regulate stable combustion conditions in the burner chamber throughout the year. Not using Tigex also increases the risk of condensation.

# Tigex 100

# Draught Stabiliser

Article Number	Description	Inner Ø	Draught Adjustable	Air group DIN 4795
60400	Tigex 100 Stainless Steel, Shiny	108	10-35 Pa	1 - 2
60402	Tigex 100 Stainless Steel, Black	108	10-35 Pa	1 - 2



60400



60402  
Powder coated black

- Gas-tight Design
- Stainless Steel
- Quiet function
- Easy to adjust
- Easy to install
- Self-cleaning door axel

# Tigex 100

# Adapter for round flue pipes

Article Number	Description	Flue pipe Ext. Ø	For use with	Air group DIN 4795
60490/80	Adapter for round flue pipe	80	Tigex 100	1 - 2
60490/90	Adapter for round flue pipe	90	Tigex 100	1 - 2
60490/100	Adapter for round flue pipe	100	Tigex 100	1 - 2
60490/110	Adapter for round flue pipe	110	Tigex 100	1 - 2
60490/120	Adapter for round flue pipe	120	Tigex 100	1 - 2

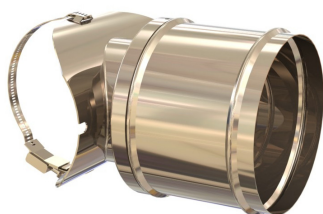

60490/90



60400 + 60490/90  
Tigex 100 with adapter for round 100 mm flue pipe

- Stainless Steel
- Easy to install
- Including closure strap

# Tigex 100

# Protection Grid

Article Number	Description	For use with
60411	Protection Grid, Stainless Steel, Shiny	Tigex 100
60412	Protection Grid, Steel, Powder Coated, Black	Tigex 100



60411

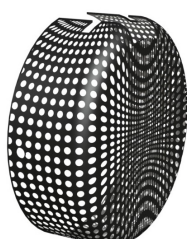

60412  
Powder coated black

- Protection Grid
- Safety



60402 + 60412  
Tigex 100 + Protection grid



# Tigex 150

# Draught Stabiliser

Article Number	Description	Inner Ø	Draught Adjustable	Air goup DIN 4795
61500	Tigex 150 Stainless Steel, Shiny	150	10-35 Pa	1 - 4
61502	Tigex 150 Stainless Steel, Black	150	10-35 Pa	1 - 4



61500



61502  
Powder coated black

- Gas-tight Design
- Stainless Steel
- Quiet function
- Easy to adjust
- Easy to install
- Self-cleaning door axel

# Tigex 150

# Adapter for round flue pipes

Article Number	Description	Flue pipe Ext. Ø	For use with	Air goup DIN 4795
61590/130	Adapter for round flue pipe	130	Tigex 150	1 - 4
61590/150	Adapter for round flue pipe	150	Tigex 150	1 - 4
61590/180	Adapter for round flue pipe	180	Tigex 150	1 - 4
61590/200	Adapter for round flue pipe	200	Tigex 150	1 - 4

- Stainless Steel
- Easy to install
- Including closure strap



61590/150

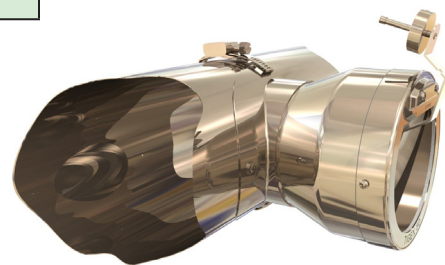

61500 + 61590/130  
Tigex 150 + Adapter for round flue pipe

# Tigex 150

# Protection Grid

Article Number	Description	For use with
61611	Protection Grid, Stainless Steel, Shiny	Tigex 150
61612	Protection Grid, Steel, Powder Coated, Black	Tigex 150

- Protection Grid
- Safety



61611

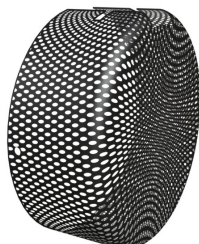

61612  
Powder coated black



# Tigex 180

# Draught Stabiliser

Article Number	Description	Inner Ø	Draught Adjustable	Air group DIN 4795
61800	Tigex 180 Stainless Steel, Shiny	180	10-35 Pa	1 - 5
61802	Tigex 180 Stainless Steel, Black	180	10-35 Pa	1 - 5



61800



61802  
Powder coated black

- Gas-tight Design
- Stainless Steel
- Quiet function
- Easy to adjust
- Easy to install
- Self-cleaning door axel

# Tigex 180

# Adapter for round flue pipes

Article Number	Description	Flue pipe Ext. Ø	For use with	Air group DIN 4795
61890/200	Adapter for round flue pipe	200	Tigex 180	1 - 5
61890/250	Adapter for round flue pipe	250	Tigex 180	1 - 5

- Stainless Steel
- Easy to install
- Including closure strap



61890/200

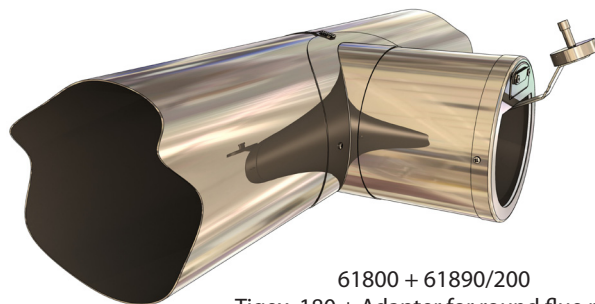

61800 + 61890/200  
Tigex 180 + Adapter for round flue pipe

# Other Adapters (ask factory)



61598/150  
Adapter for round flue pipe with  
Explosion relief adapter Tigex 150



61501 + 61595/200  
Tigex 150 + Adapter for T-pipe

And many  
more...

# New Products

## Tigex 180

The new Tigex 180 has been designed as the next step in the Tigex family of development. The Tigex 180 is designed and tested to meet the requirements of DIN 4795 air group 5. This Draught Stabiliser is perfect for larger boiler installations up to 250 kW.

The Tigex 180 is made with the same ingenious, gas-tight design, which allows the damper flap to close tight against the seal. By mounting the door (flap) axel on the back side, there is no leakage of exhaust fumes through hinge or axel joints. This allows the Tigex 180 to close completely tight. The axel joint is also self-cleaning.



## New Adapter for installations on 80 mm flue pipe

The Tigex 100 (Air group 2 according to DIN 4795) is the perfect Draught Stabiliser for installations on small chimney or flue pipes commonly used on stoves. We now have a series of adapters to fit on pipe sizes Ø80, 90, 100, 110 and 120 mm.

The Tigex 150 (Air group 4 according to DIN 4795) is the next Draught Stabiliser size with adapters from Ø130, 150, 180 and 200 mm.

Finally, we have now introduced the new Tigex 180 (Air group 5 according to DIN 4795), our largest Draught Stabiliser with adapters from Ø200 to 250 mm.



SPX Flow Technology Sweden AB, Bryggavägen 113, 178 31 Ekerö, Sweden  
Phone: +46 8 560 340 30 Fax: +46 8 560 342 60  
E-mail: [tigerholm@spx.com](mailto:tigerholm@spx.com)

For more information about our worldwide locations, approvals, certifications, and local representatives, please visit [www.tigerholm.com](http://www.tigerholm.com).

SPX Corporation reserves the right to incorporate our latest design and material changes without notice or obligation.

Design features, materials of construction and dimensional data, as described in this bulletin, are provided for your information only and should not be relied upon unless confirmed in writing.

Issued: 01/2009 Copyright © 2008 SPX Corporation

